

## CULTIVAR RELEASE

<http://dx.doi.org/10.1590/1984-70332015v15n3c32>

### RB99395: Sugarcane cultivar with high sucrose content

Geraldo Veríssimo de Souza Barbosa<sup>1,2\*</sup>, Ricardo Augusto de Oliveira<sup>1</sup>, Marcelo de Menezes Cruz<sup>2</sup>, João Messias dos Santos<sup>2</sup>, Paulo Pedro da Silva<sup>2</sup>, Antônio Jorge de Araújo Viveiros<sup>2</sup>, Antônio José Rosário Sousa<sup>2</sup>, Carlos Alberto Guedes Ribeiro<sup>2</sup>, Lailton Soares<sup>2</sup>, Iêdo Teodoro<sup>2</sup>, Francisco Sampaio Filho<sup>2</sup>, Carlos Assis Diniz<sup>2</sup> and Vera Lúcia Dubeux Torres<sup>2</sup>

Received 16 August 2013

Accepted 09 February 2014

**Abstract** – RB99395 cultivar was developed by the Sugarcane Breeding Program at the Federal University of Alagoas, which is part of RIDESEA. In 1999, seeds were obtained from crosses between RB867515 cultivar and pollen from an unknown genotype in “Serra do Ouro” Crossing Station. The process of selection and experimentation was carried out in three Research Stations of Alagoas. RB99395 cultivar was released in Alagoas in May 2010, and has a high content of sucrose throughout the harvest period. Planting is recommended in fertile soils and in environments with no water deficiency, a condition which results in high agricultural yields. It is tolerant most diseases that occur in Northeast, Brazil.

**Key words:** *Saccharum spp.*, plant breeding, cultivar description.

## INTRODUCTION

The Genetic Sugarcane Breeding Program, located in the Center for Agricultural Science of the Federal University of Alagoas, integrates the Inter-University Network for the Development of the Sugarcane Industry – RIDESEA (Melo et al. 2014, Iaia et al. 2015). It has the objective of obtaining RB (Republic of Brazil) cultivars with high sugar yield, a characteristic which depends on the mass of stalks per unit area, and sucrose content of stalks. In the development of RB cultivars (Germplasm Bank of Serra do Ouro Flowering and Crossing Station) (Santos et al. 2014, Silva et al. 2015), around 300 thousand seedlings per year are planted in eight distinct environments of Alagoas, followed by stages of phenotypic selection, experimentation, maturation curve, disease assessment and multiplication of clones in production areas (Barbosa et al. 2002, Brasileiro et al. 2015). In clones selection processes, drought tolerance and non-flowering characteristics are also considered. RB99395 cultivar (*Saccharum spp.*), with the Protection Certificate n° 20120048 - SNPC/MAPA, was released in Alagoas in May 2010 (Barbosa et al. 2012). Through the harvest period, this cultivar presented high sugar yield, early maturation and maintenance of high levels of sucrose. In order to achieve larger gains of high sugar content, it is recommended to be

planted in high potential yield environments, i.e., in areas with no water deficiency, and in fertile soils. Environment understanding is what will indicate the correct management of the appropriate seasons for planting and harvesting the cultivar.

## PEDIGREE AND GENETIC BREEDING METHODOLOGY

The pedigree of RB99395 is shown in Figure 1. It is a cultivar of a long-term recurrent selection program carried out by RIDESEA. The female parent is the cultivar RB867515,

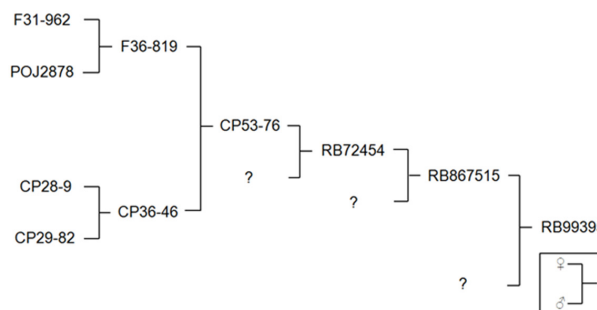

**Figure 1.** Pedigree of RB99395 cultivar.

<sup>1</sup> Universidade Federal do Paraná (UFPR), Departamento de Fitotecnia e Fitossanitarismo, Rua dos Funcionários, 1540, 80.035-050, Juvevê, Curitiba, PR, Brazil.

\*E-mail: gvsbarbosa@gmail.com

<sup>2</sup> Universidade Federal de Alagoas (UFAL), Centro de Ciências Agrárias, BR 104, Norte, km 85, 57.100-000, Rio Largo, AL, Brazil

which has high yield of cane and sucrose. RB867515 cultivar was developed by the Sugarcane Breeding Program at the Federal University of Viçosa (Barbosa et al. 2001), and reached 22.1% of the sugarcane cultivated area in Brazil in 2011 (Barbosa et al. 2012). The female parent of RB867515 cultivar is RB72454 (developed by PLANAL-SUCAR), which has high yield potential, and reached 20% of the total area cultivated with sugar cane of Brazil in 1995 (Barbosa et al. 2012).

Hybridization occurred in May 1999 at Serra do Ouro Flowering and Breeding Station (Murici, Alagoas, lat 09° 13' S, long 35° 50' W and alt 515 m asl), using polycross in pollination of RB867515 cultivar female flowers. In July 1999, seeds of this crossing were germinated in a greenhouse at the Center for Agricultural Science, Federal University of Alagoas, in Rio Largo, Alagoas (lat 09° 28' S, long 35° 49' W and 127 m asl). In September 1999, nineteen thousand, nine hundred and forty-six (19,946) seedlings of the RB99 series were transplanted into the field, in São Miguel dos Campos, Alagoas (lat 09° 42' S, long 36° 06' W and 132 asl), spaced one meter between rows and 0.5 meter between seedlings.

The plant-cane was harvested in November 2000, and proceeded to the selection of first stage -  $T_1$  (first-ratoon crops) in September 2001, based on the following characteristics: number of stalks per clump, development, plant health, and the Brix values (% soluble solids in the juice extracted from stalks). After selection, 216 RB99 series clones were planted in the same place, in plots of two rows of three meter each, spaced one meter apart, and 18 sugarcane buds were distributed per linear meter in order to start the second selection stage ( $T_2$ ). In September 2003, the selection of  $T_2$  was also carried out in the first-ratoon crops,

and based on the same characteristics as  $T_1$ . In  $T_3$  stage, 41 clones of the RB99 series were planted in the same place, in addition to cultivar SP79-1011 (standard), in plots of five 4m long rows, in randomized complete block designs, with two replications, and with 18 sugarcane buds per linear meter. The selection of  $T_3$  was carried out considering the data collected for plant-cane and the first-ratoon crops, by observing the characteristics of cane yield ( $t\ ha^{-1}$ ), percentage of apparent sucrose in cane juice (Pol % cane), determined according to the method described by Fernandes (2003), and apparent sucrose yield ( $t\ Pol\ ha^{-1}$ ).

The experimental stage was initiated in 2005. Between 2005-2009, 14 experiments were carried out in three sugarcane regions in Alagoas: São Miguel dos Campos (lat 09° 42' S, long 36° 06' W and alt 132 asl), Coruripe (lat 10° 8' S, long 36° 11' W and alt 69 asl) and São Luiz do Quitunde (lat 09° 22' S, long 35° 32' W and alt 31 asl). Each experiment consisted of 20 clones of the RB99 series, in addition to cultivar SP79-1011 (standard), in randomized complete block designs with four replications, in plots of six 6m long rows, and 18 sugarcane buds per linear meter. The experiments were harvested in cane-plant, first and second-ratoon crops. In this stage, the genotypes were evaluated in relation to cane yield ( $t\ ha^{-1}$ ), percentage of apparent sucrose in cane juice (Pol % cane), apparent sucrose yield ( $t\ Pol\ ha^{-1}$ ), response to the main diseases in the region, as well as adaptability and phenotypic stability (Eberhart and Russell 1966). Moreover, the maturation curve of RB99395 was evaluated in relation to SP79-1011 during the sugarcane harvest period in Alagoas, from September 2006 to February 2007, at the same experimental fields. Since RB99395 showed advantageous results in field trials, it was intensely multiplied in the mill areas of the productive sector of the region, which allowed the verification of the most appropriate

**Table 1.** Mean of cane yield ( $t\ ha^{-1}$ ), percentage of apparent sucrose (Pol % cane), and apparent sucrose per hectare ( $t\ Pol\ ha^{-1}$ ) of RB99395 and SP79-1011, according to the crop cycle and to the estimated gain of the released cultivar. Mean results from 25 harvesting experiments

Variables	Harvest	RB99395	SP79-1011	Difference*	%
Cane yield ( $t\ ha^{-1}$ )	Plant-cane	127.05	107.93	19.12	17.72
	First-ratoon	99.59	87.87	11.72	13.34
	Second-ratoon	108.94	104.88	4.06	3.87
	Mean	116.09	101.14	14.94	14.78
Pol % cane	Plant-cane	15.73	14.67	1.06	7.23
	First-ratoon	15.77	14.60	1.17	8.01
	Second-ratoon	16.86	15.69	1.17	7.46
	Mean	15.88	14.77	1.11	7.50
$t\ Pol\ ha^{-1}$	Plant-cane	19.98	15.83	4.15	26.22
	First-ratoon	15.71	12.83	2.88	22.42
	Second-ratoon	18.37	16.46	1.91	11.62
	Mean	18.42	14.95	3.47	23.25

\* Difference of sugar yields of RB99395 considering SP79-1011 as reference.

crop management. When RB99395 cultivar was released to producers, data from 25 harvest experiments was gathered, which allowed testament to its superior qualities.

**PERFORMANCE**

The mean results of 25 experimental harvests (14 from the plant-cane, eight from the first-ratoon and three from the second-ratoon) showed superiority in sugar yields in the three harvest cycles of RB99395 cultivar, in comparison to SP79-1011 (Table 1). The mean gain in cane yield was 14.94 t ha<sup>-1</sup> (14.78% increment), and 1.11 for Pol % cane (7.50% increment). Given the simultaneous superiority in agricultural yield and apparent sucrose content, the gain was even more significant for apparent sucrose yield (difference of 3.47, or 23.25% in t Pol ha<sup>-1</sup>).

In the period from 1998 to 2008 in Alagoas, the cultivar SP79-1011 reached 30% of the total area planted by the producers due to its high sucrose content, early maturity and stability in agricultural production (Barbosa et al. 2008). The maturation curve of RB99395 cultivar is represented by the accumulation of sucrose (Pol % cane) during the months of harvest, determined according to the method described by Fernandes (2003). In the sugarcane harvest conditions of Alagoas, a much superior performance for the maturing of RB99395 cultivar was found - indicating a long useful period of industrialization - with the most advantageous results between the months of November to January (Figure 2).

When the performance of sugar yields of RB99395 cultivar (cane yield in t ha<sup>-1</sup>, Pol % cane and t Pol ha<sup>-1</sup>) was evaluated according to the environmental condition, following the methodology of Eberhart and Russell (1966), the

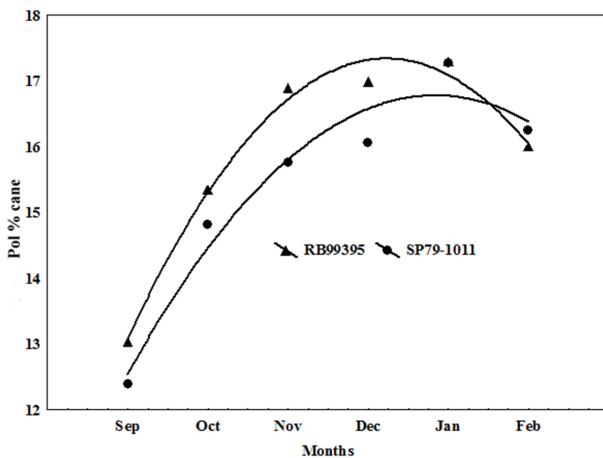

**Figure 2.** Maturation curves of RB99395 and SP79-1011 for the variable percentage of apparent.

results of 14 harvest experiments (plant-cane) found that RB99395 has yield stability and responds to environmental improvement. RB99395 cultivar has higher sugar yield than SP79-1011 cultivar in various environments (Figure 3).

With regard to reaction to major diseases, RB99395 showed tolerance to the two most important ones that occur in Alagoas, Brown Rust (*Puccinia melanocephala*) and Leaf Scald (*Xanthomonas albilineans*). It was moderately susceptible to Smut (*Sporisorium scitamineum*, synonym *Ustilago scitaminea*), which presents low incidence in

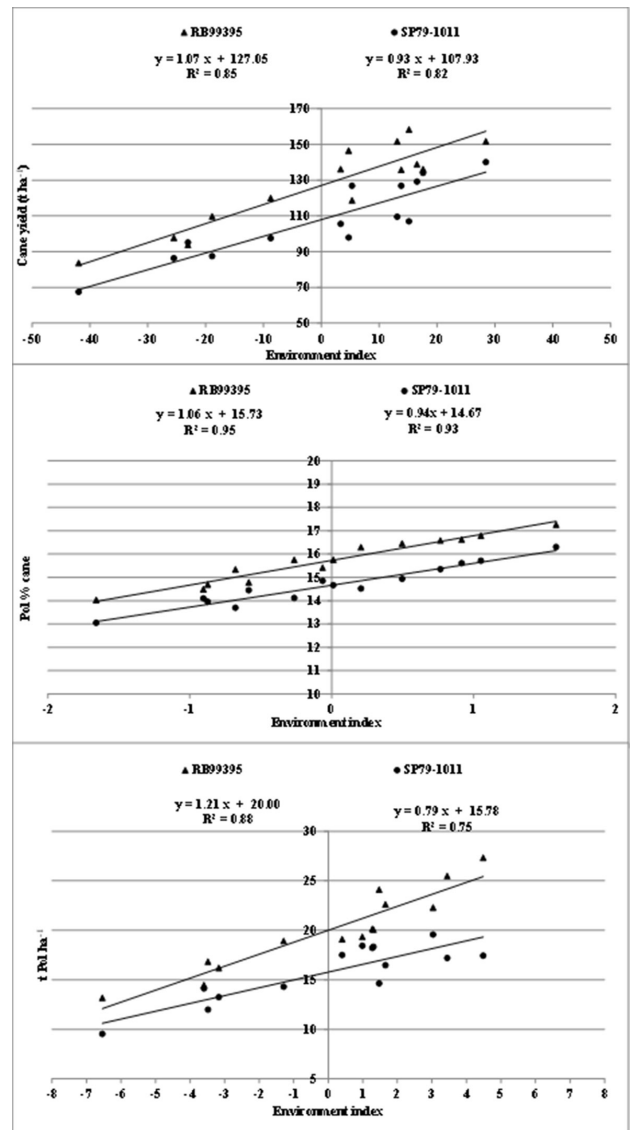

**Figure 3.** Mean of cane yield (t ha<sup>-1</sup>), percentage of apparent sucrose (Pol % cane) and t Pol ha<sup>-1</sup> from RB99395 and SP79-1011, with adjusted linear regression, according to the environment index of 14 experiments in Alagoas.

Alagoas and in Northeast, Brazil.

## OTHER CHARACTERISTICS

RB99395 cultivar has good sprouting, average tillering, regular growth rate and good canopy closure between rows. It has slightly decumbent growth habit, and the leaf canopy volume is regular. Leaves are arched, of medium width and slightly serrated on the margins. It has a crescent ligule, a deltoid, small and symmetrical auricle. The dewlap is triangular and purple. Its sheaths, with pilosity on the back, have purplish-green color, with little wax, and it is of easy removal. The top of the stalk is short and has little wax. Its stalk has cylindrical internodes, with a circular cross section, arranged in gentle zigzag, with an average length and diameter; it has a smooth look, yellowish-purple color under the chaff, and it gets yellowish-green when it is exposed to the sun, with absence of cracks, and little wax. Its growth

## REFERENCES

- Barbosa GVS, Cruz MM, Soares L, Rocha AMC, Ribeiro CAG, Souza AJR, Ferreira JLC, Barreto EJS, Silva WCM and Santos AVP (2002) A brief report on sugarcane breeding program in Alagoas, Brazil. **Crop Breeding and Applied Biotechnology** 4: 613-616.
- Barbosa GVS, Silva PP, Santos JM, Cruz MM, Souza AJR, Ribeiro CAG, Ferreira JLC, Sampaio Filho F, Santos TWT, Nascimento BFC, Silva WT and Almeida BFA (2008) Desempenho agroindustrial e censo de variedades de cana-de-açúcar cultivadas no Estado de Alagoas. In **IX Congresso nacional da sociedade dos técnicos açucareiros e alcooleiros do Brasil**. STAB, Maceió, p. 464-470.
- Barbosa MHP, Silveira LCI, Oliveira MW, Souza VFM and Ribeiro SNN (2001) RB867515 Sugarcane cultivar. **Crop Breeding and Applied Biotechnology** 4: 437-438.
- Barbosa MHP, Resende MDV, Dias LAS, Barbosa GVS, Oliveira RA, Peternelli LA and Daros E (2012) Genetic improvement of sugar cane for bioenergy: the Brazilian experience in network research with RIDESA. **Crop Breeding and Applied Biotechnology** S2: 87-98.
- Brasileiro BP, Marinho CD, Costa PMA, Cruz CD, Peternelli LA and Barbosa MHP (2015) Selection in sugarcane families with artificial

ring is greenish-yellow, wide, with average protrusions, with narrow root area and no aerial roots, with purplish-yellow primordial roots. Its bud is obovate, small and has little prominence, and never exceeds the growth ring, with a narrow cushion, with the presence of bristles on the apex, and with apical germ pore. It has shallow grooves and a little accentuated leaf scars. Its flowering occurs especially in years with favorable weather for this physiological event.

## MAINTENANCE OF GERMPLASM AND DISTRIBUTION OF SEEDLINGS

Plants of RB99395 cultivar are kept in the clonal garden by the breeding program of the Center for Agricultural Science of the Federal University of Alagoas (BR 104, North, km 85 - 57.100.000, Rio Largo, Alagoas), and seedlings are multiplied in advanced research bases for the distribution to producers.

neural networks. **Crop Breeding and Applied Biotechnology** 15: 72-78.

Eberhart SA and Russell WA (1966) Stability parameters for comparing varieties. **Crop Science** 6: 36-40.

Fernandes AC (2003) **Cálculos na agroindústria da cana-de-açúcar**. 2<sup>th</sup> edn, EME, Piracicaba, 240p.

Iaia AM, Oliveira RA, Melo LJOT, Daros E, Simões Neto DE, Bastos GQ, Oliveira FJ, Chaves A and Melo TTAT (2014) RB002504 – New early-maturing sugarcane cultivar. **Crop Breeding and Applied Biotechnology** 14: 45-47.

Melo LJOT, Daros E, Simões Neto DE, Chaves A, Silva LJ, Silva AEP and Melo TTAT (2014) RB962962, a sugarcane cultivar for late harvest. **Crop Breeding and Applied Biotechnology** 14: 132-135.

Santos JM, Barbosa GVS, Ramalho Neto CE and Almeida C (2014) Efficiency of biparental crossing in sugarcane analyzed by SSR markers. **Crop Breeding and Applied Biotechnology** 14: 102-107.

Silva FL, Barbosa MHP, Resende MDV, Peternelli LA and Pedrozo CA (2015) Efficiency of selection within sugarcane families via simulated individual BLUP. **Crop Breeding and Applied Biotechnology** 15: 1-9.